

Panasonic[®]

Operating Instructions

Microwave Oven
Models NN-S432WL
NN-S432BL



This manual contains Safety Instructions, Operating Instructions and Maintenance of the oven.
Before operating this oven, please read these Instructions completely.
Antes de operar este producto, lee este instructivo en su totalidad.
El manual de instrucciones en español puede ser encontrada en la páginas 24-31
(Spanish Operating Instructions can be found on pages 24-31)

For assistance, please call 1-800-211-PANA(7262)
or send e-mail to consumerproducts@panasonic.com
or visit us at www.panasonic.com

(U.S.A)

For assistance, please call : 787-750-4300
or visit us at www.panasonicpr.com

(Puerto Rico)

Thank you for purchasing the Panasonic Microwave Oven.

PRECAUTIONS TO AVOID POSSIBLE EXPOSURE TO EXCESSIVE MICROWAVE ENERGY

- (a) Do not attempt to operate this oven with the door open since open-door operation can result in harmful exposure to microwave energy. It is important not to defeat or tamper with the safety interlocks. Under normal conditions oven will not operate with door open.
- (b) Do not place any object between the oven front face and the door or allow soil or cleaner residue to accumulate on sealing surfaces.
- (c) Do not operate the oven if it is damaged. It is particularly important that the oven door close properly and that there is no damage to the:
 - (1) door (bent),
 - (2) hinges and latches (broken or loosened),
 - (3) door seals and sealing surfaces.
- (d) The oven should not be adjusted or repaired by anyone except properly qualified service personnel.

Technical Specifications

	NN-S432WL/BL
Power Source:	120 V, 60 Hz
Power Consumption:	13.0 Amps, 1,500 W
Output*:	1,100 W
Outside Dimensions (H x W x D):	12" x 20 ¹ / ₈ " x 15 ¹³ / ₁₆ " (303.8 x 514.7 x 408 mm)
Oven Cavity Dimensions (H x W x D):	9 ⁵ / ₁₆ " x 13 ⁷ / ₈ " x 14 ³ / ₁₆ " (236 x 353 x 361mm)
Operating Frequency:	2,450 MHz
Uncrated Weight:	Approx. 33.1 lbs. (15.0 kg)

*IEC 60705 RATING STANDARD Specifications subject to change without notice.

The serial number of this product may be found on the back side of the oven. You should note the model number and the serial number of this oven in the space provided and retain this book as a permanent record of your purchase for future reference.

Model No. _____

Serial No. _____

Date of Purchase _____

Contents

Before Operating

Precautions	Inside Front Cover
Important Safety Instructions	4
Installation and Grounding Instructions	5
Safety Precautions	6
Cookware and Utensil Guide	7
Feature Diagram	8
Control Panel	8

Operation

Clock Setting	9
Child Safety Lock	9
Quick Min Function	9
Timer Setting	9
Power & Time Setting	10
Multi-Stage Cooking	11
Auto Defrost	11
Auto Defrost Chart	12
Auto Cook	13
Auto Cook Chart	13
Food Characteristics	14
Cooking Techniques	14-15
Using Your Microwave Oven	16-17
Heating or Reheating Guide	18
Fresh Vegetable Chart	19
Quick Guide to Operation	Back Cover

Maintenance

Technical Specifications	Inside Front Cover
Care of Your Microwave Oven	20
Before Requesting Service	21
Limited Warranty & Customer Services	22-23

Manual de instrucciones (Spanish Operating Instructions)

Instrucciones de Seguridad	24 - 25
Instrucciones para Conexión a Tierra	25
Instrucciones de Instalación	26
Sugerencias Útiles	27
Panel de Control	28
El poder & el tiempo poniendo	28
Niveles de intensidad de las microondas	29
Trace para el cocinero automatico	30
Guía Rápida de Operación	31

IMPORTANT SAFETY INSTRUCTIONS



Your microwave oven is a cooking device and you should use as much care as you use with a stove or any other cooking device. When using this electric appliance, basic safety precautions should be followed, including the following:

WARNING—To reduce the risk of burns, electric shock, fire, injury to persons, or exposure to excessive microwave energy:

1. Read all instructions before using the appliance.
2. Read and follow the specific **"PRECAUTIONS TO AVOID POSSIBLE EXPOSURE TO EXCESSIVE MICROWAVE ENERGY,"** found on the inside front cover.
3. This appliance must be grounded. Connect only to properly grounded outlet. See **"GROUNDING INSTRUCTIONS"** found on page 5.
4. Install or locate this appliance only in accordance with the installation instructions found on page 5.
5. Do not cover or block any openings on this appliance.
6. Do not store or use this appliance outdoors.
Do not use this product near water—for example, near a kitchen sink, in a wet basement, or near a swimming pool, and the like.
7. Use this appliance only for its intended use as described in this manual. **DO NOT** use corrosive chemicals, vapors, or non-food products in this appliance. This type of oven is specifically designed to heat or cook. It is not designed for industrial or laboratory use. The use of corrosive chemicals in heating or cleaning will damage the appliance and may result in radiation leaks.
8. When cleaning surfaces of door and oven that come together on closing the door, use only mild, non-abrasive soaps or detergents applied with a sponge or soft cloth.
9. Do not allow children to use this appliance, unless closely supervised by an adult.
10. Do not operate this appliance if it has a damaged cord or plug, if it is not working properly, or if it has been damaged or dropped.
11. Do not immerse cord or plug in water.
12. Keep cord away from heated surfaces.
13. Do not let cord hang over edge of a table or counter.
14. This appliance should be serviced only by qualified service personnel. Contact the nearest authorized servicenter for examination, repair or adjustment.
15. Some products such as whole eggs, narrow neck bottles and sealed containers—for example, closed glass jars—may explode and should not be heated in this oven.

16. To reduce the risk of fire in the oven cavity:
 - (a) Do not overcook food. Carefully attend appliance if paper, plastic, or other combustible materials are placed inside the oven to facilitate cooking.
 - (b) Remove wire twist-ties from paper or plastic bags before placing bag in oven.
 - (c) **If materials inside the oven should ignite, keep oven door closed, turn oven off, and disconnect the power cord, or shut off power at the fuse or circuit breaker panel.**
 - (d) Do not use the cavity for storage purposes. Do not leave paper products, cooking utensils, or food in the cavity when not in use.

General Use

1. **DO NOT** tamper with or make any adjustments or repairs to door, Control Panel housing, safety interlock switches or any other part of the oven. **DO NOT** remove outer panel from oven. Repairs should only be done by a qualified service person.
2. **DO NOT** operate the oven empty. The microwave energy will reflect continuously throughout the oven causing overheating, if food or water is not present to absorb energy. This could damage the oven and result in the risk of a fire.
3. **DO NOT** dry clothes, newspapers or other materials in oven, or use newspapers or paper bags for cooking. Fire could result.
4. **DO NOT** use recycled paper products unless the paper product is labeled as safe for microwave oven use. Recycled paper products may contain impurities which may cause sparks, and result in fires when used.
5. **DO NOT** hit or strike Control Panel. Damage to controls may occur. Fire could result.
6. **POT HOLDERS** should always be used when removing items from the oven. Heat is transferred from the **HOT** food to the cooking container and from the cooking container to the Glass Tray. The Glass Tray can be very **HOT** after removing the cooking container from the oven.
7. **DO NOT** store flammable materials next to, on top of, or in the oven. These could be fire hazards.

SAVE THESE INSTRUCTIONS

For proper use of your oven read remaining safety cautions and operating instructions.

Installation and Grounding Instructions

Examine Your Oven

Unpack oven, remove all packing material and examine the oven for any damage such as dents, broken door latches or cracks in the door. Notify dealer immediately if oven is damaged. **DO NOT** install if oven is damaged.

Placement of Oven

1. Oven must be placed on a flat, stable surface. For proper operation, the oven must have sufficient air flow. Allow 4-inches (10 cm) of space on both sides and top of oven.
 - a. **DO NOT** block air vents.
If they are blocked during operation, the oven may be overheated and damaged. When using any cloth over the oven, the air intake and exhaust should not be blocked. Also should allow space on back and both sides of oven properly.
 - b. **DO NOT** place oven near a hot, damp surface such as a gas or electric range, or dishwasher.
 - c. **DO NOT** operate oven when room humidity is too high.
2. This oven was manufactured for household use only.

Grounding Instructions

This appliance must be grounded. In the event of an electrical short circuit, grounding reduces the risk of electric shock by providing an escape wire for the electric current. This appliance is equipped with a cord having a grounding wire with a grounding plug. The plug must be plugged into an outlet that is properly installed and grounded.

WARNING—Improper use of the grounding plug can result in a risk of electric shock.

Consult a qualified electrician or service person if the grounding instructions are not completely understood, or if doubt exists as to whether the appliance is properly grounded. If it is necessary to use an extension cord, use only a three wire extension cord that has a three blade grounding plug, and a three slot receptacle that will accept the plug on the appliance. The marked rating of the extension cord should be equal to or greater than the electrical rating of the appliance.

Power Supply

1. A short power-supply cord is provided to reduce the risks resulting from becoming entangled in or tripping over a longer cord.
2. Longer cord sets or extension cords are available and may be used if care is exercised in their use.
3. If a long cord or extension cord is used, (1) the marked electrical rating of the cord set or extension cord should be at least as great as the electrical rating of the appliance, (2) the extension cord must be a grounding-type 3-wire cord, and (3) the longer cord should be arranged so that it will not drape over the counter top or tabletop where it can be pulled on by children or tripped over accidentally.

Wiring Requirements

1. The oven must be on a **SEPARATE CIRCUIT**. No other appliance should share the circuit with the microwave oven. If it does, the branch circuit fuse may blow, the circuit breaker may trip, or the food may cook slower than the times recommended in this manual.
2. The **VOLTAGE** used must be the same as specified on this microwave oven (120 V, 60 Hz). Using a higher voltage is dangerous and may result in a fire or other incident causing oven damage. Using a lower voltage will cause slow cooking. Panasonic is **NOT** responsible for damage resulting from the use of the oven with other than the specified voltage.
3. The oven must be plugged into at least a **20 AMP, 120 VOLT, 60 Hz GROUNDED OUTLET**. Where a standard two-prong outlet is encountered, it is the personal responsibility and obligation of the consumer to have it replaced with a properly grounded three-prong outlet.



TV / Radio Interference

1. Operation of the microwave oven may cause interference to your radio, TV or similar equipment.
2. When there is interference, it may be reduced or eliminated by taking the following measures:
 - a. Clean door and sealing surfaces of the oven. (See Care of Your Microwave Oven)
 - b. Place the radio, TV, etc. away from the microwave oven as far as possible.
 - c. Use a properly installed antenna to obtain stronger signal reception.

Glass Tray

1. **DO NOT** operate the oven without Rotating Ring and Glass Tray in place.
2. **DO NOT** operate the oven without the Glass Tray fully engaged on the drive hub. Improper cooking or damage to the oven could result. Verify that the Glass Tray is properly engaged and rotating by observing its rotation when you press **Start**.
3. Only use the Glass Tray specifically designed for this oven. Do not substitute any other glass tray.
4. If the Glass Tray is hot, allow to cool before cleaning or placing in water.
5. **DO NOT** cook directly on the Glass Tray. Always place food in a microwave-safe dish, or on a rack set in a microwave-safe dish.
6. If food or utensil on Glass Tray touches oven walls, causing the tray to stop moving, the tray will automatically rotate in the opposite direction. This is normal.
7. Glass Tray can turn in either direction.

Rotating Ring

1. Rotating Ring and oven floor should be cleaned frequently to prevent excessive noise.
2. Rotating Ring must always be used for cooking along with Glass Tray.
3. Always replace Rotating Ring and Glass Tray in their proper positions.

Safety Precautions

Follow These Safety Precautions When Cooking in Your Oven

IMPORTANT

Proper cooking depends upon the power, the time set and the quantity of food. If you use a smaller portion than recommended and cook at the time for the recommended portion, fire can result.

1) HOME CANNING / DRYING FOODS / SMALL QUANTITIES OF FOODS

- **DO NOT** use your oven for home canning, your oven cannot maintain the food at the proper canning temperature. Improperly canned food may spoil and be dangerous to consume.
- **DO NOT** dry meats, herbs, fruits or vegetables in your oven. Small quantities of food or foods with low moisture content can dry out, scorch or catch on fire if overheated.

2) POPCORN

Popcorn may be popped in a microwave oven corn popper. Microwave popcorn which pops in its own package is also available. Follow popcorn manufacturers' directions and use a brand suitable for the wattage of your microwave oven.

CAUTION: When using pre-packaged microwave popcorn, follow recommended package instructions. Check package weight before using the Popcorn pad (see Popcorn Pad section). Set the oven for the weight of the popcorn package.

If these instructions are not followed, the popcorn may not pop adequately or may ignite and cause a fire. Never leave oven unattended when popping popcorn. Allow the popcorn bag to cool before opening, always open the bag away from your face and body to prevent steam burns.

3) DEEP FAT FRYING

- **DO NOT** attempt to deep fat fry in your microwave oven. Cooking oils may burst into flames and may cause damage to the oven and perhaps result in burns. Microwave utensils may not be able to withstand the temperature of the hot oil, and could shatter or melt.

4) FOODS WITH NONPOROUS SKINS

- Potatoes, apples, whole eggs, egg yolks, whole squash and sausages are examples of foods with nonporous skins. These types of foods must be pierced before microwave cooking to prevent their bursting.
- Use fresh potatoes for baking and cook until just done. Use recommended weights for programmed cooking. Overcooking causes dehydration and may result in a fire.

5) LIQUIDS

- Liquids can become "superheated" in a microwave, and when the container is moved in any way, the **superheated liquids can "explode" out of the container.** "Superheated" water is hotter than boiling water, **EVEN THOUGH IT DOES NOT APPEAR TO BUBBLE.** To reduce the possibility

of this occurrence:

Always make sure that liquids are stirred vigorously before heating to assure that the liquid is mixed with air. **NEVER HEAT LIQUIDS FOR AN EXCESSIVE LENGTH OF TIME.**

6) GLASS TRAY / COOKING UTENSILS / FOIL

- Cooking utensils get hot during microwaving. Heat is transferred from the **HOT** food to the container and the Glass Tray. Use potholders when removing utensils from the oven or when removing lids or plastic wrap covers from cooking utensils to avoid burns.
- The Glass Tray will get hot during cooking. It should be allowed to cool before handling or before paper products, such as paper plates or microwave popcorn bags, are placed in the oven for microwave cooking.
- When using foil, skewers, warming rack or utensils made of metal in the oven, allow at least 1-inch (2.5 cm) of space between metal material and interior oven walls. If arcing occurs (sparking), remove metal material (skewers etc.) and/or transfer to a non-metallic container.
- Dishes with metallic trim should **not** be used, as arcing may occur.
- If an entree is heated in a foil tray, maintain at least 1-inch (2.5 cm) spacing from the oven walls.

7) PAPER TOWELS / CLOTHS

- **DO NOT** use paper towels or cloths which contain a synthetic fiber woven into them. The synthetic fiber may cause the towel to ignite. Use paper toweling under supervision.

8) BROWNING DISHES / OVEN COOKING BAGS

- Browning dishes or grills are designed for microwave cooking only. Always follow instructions provided by the manufacturer. **DO NOT** preheat browning dish more than 6 minutes.
- If an oven cooking bag is used for microwave cooking, prepare according to package directions. **DO NOT** use a wire twist-tie to close bag, instead use plastic ties, cotton string or a strip cut from the open end of the bag.

9) THERMOMETERS

- **DO NOT** use a conventional meat thermometer in your oven. Arcing may occur. Microwave-safe thermometers are available for both meat and candy.

10) BABY FORMULA / FOOD

- **DO NOT** heat baby formula or food in the microwave oven. The glass jar or surface of the food may appear to be only warm while the interior can be so hot as to burn the infant's mouth and esophagus.

11) REHEATING PASTRY PRODUCTS

- When reheating pastry products, check temperatures of any fillings before eating. Some foods have fillings which heat faster and can be extremely hot, while the surface remains warm to the touch (ex. Jelly Donuts).

12) GENERAL OVEN USAGE GUIDELINES

- **DO NOT** use the oven for any reason other than the preparation of food.
- **DO NOT** leave oven unattended while in use.

Cookware and Utensil Guide

ITEM	MICROWAVE	COMMENTS
Aluminum Foil	Yes for Shielding only	Small strips of foil can be molded around thin parts of meat or poultry to prevent overcooking. Arcing can occur if foil is too close to oven wall or if too much foil is used.
Browning Dish	Yes	Browning dishes are designed for microwave cooking only. Check browning dish information for instructions and heating chart. Do not preheat for more than 6 minutes.
Brown paper bags	No	May cause a fire in the oven.
Dinnerware Labeled "Microwave-Safe"	Yes	Check manufacturers' use and care directions for use in microwave heating. Some dinnerware may state on the back of the dish, "Oven-Microwave Safe".
Other Dinnerware	?	Use CONTAINER TEST below.
Disposable polyester Paperboard Dishes	Yes	Some frozen foods are packaged in these dishes. Can be purchased in grocery stores.
Fast Food Carton with Metal Handle	No	Metal handle may cause arcing.
Frozen Dinner Tray Metal	Yes	Frozen dinners may be heated in foil tray, if tray is less than 3/4-in. (2 cm) high. Place foil tray in center of oven. Leave at least 1-in. (2.5 cm) space between foil tray and oven walls. Heat only 1 foil tray in the oven at a time. For containers more than 3/4-inch (2 cm) deep, remove food and place in a similar size microwave-safe container.
Microwave-safe	Yes	
Glass Jars	Yes, use caution	Remove lid. Heat food until just warm, not HOT. Most glass jars are not heat resistant. Do not use for cooking.
Glassware Heat Resistant Oven Glassware & Ceramics	Yes	Ideal for microwave cooking and browning. (See CONTAINER TEST below)
Metal Bakeware	No	Not recommended for use in microwave ovens.
Metal Twist-Ties	No	May cause arcing which could cause a fire in the oven.
Oven Cooking Bag	Yes	Follow manufacturers' directions. Close bag with the nylon tie provided, a strip cut from the end of the bag, or a piece of cotton string. Do not close with a metal twist-tie. Make six 1/2-in. (1 cm) slits near the closure.
Paper Plates & Cups	Yes	Use to warm cooked foods, and to cook foods that require short cooking times such as hot dogs.
Paper Towels & Napkins	Yes	Use to warm rolls and sandwiches by microwave.
Parchment Paper	Yes	Use as a cover to prevent spattering. Safe for use in microwave, microwave/convection and conventional ovens.
Plastic Microwave-Safe Cookware Reheat & Storage	Yes	Should be labeled, "Suitable for Microwave Heating." Check manufacturers' directions for recommended uses. Some microwave-safe plastic dishes are not suitable for cooking foods with high fat or sugar content. The heat from hot food may cause the plastic to warp.
Melamine	No	
Plastic Foam Cups	Yes, use caution	Plastic foam will melt if foods reach a high temperature. Use to bring foods to a low serving temperature.
Plastic Wrap	Yes	Use to cover food during cooking to retain moisture and prevent spattering. Should be labeled "Suitable for Microwave Heating". Check package directions.
Straw, Wicker, Wood	Yes	Use only for short term reheating and to bring food to a low serving temperature.
Thermometers Microwave-safe, only	Yes	Use only microwave-safe meat and candy thermometers. Not suitable for use in microwave oven, will cause sparks and get hot.
Conventional	No	
Wax paper	Yes	Use as a cover to prevent spattering and to retain moisture.

CONTAINER TEST

TO TEST A CONTAINER FOR SAFE MICROWAVE OVEN USE: Fill a 1-cup glass measure with water and place it in the microwave oven along with the container to be tested; **heat one (1) minute at P10 (HIGH)**. If the container is microwave oven-safe (transparent to microwave energy), the container should remain comfortably cool and the water should be hot. If the container is hot, it has absorbed some microwave energy and should NOT be used. This test cannot be used for plastic containers.

Feature Diagram

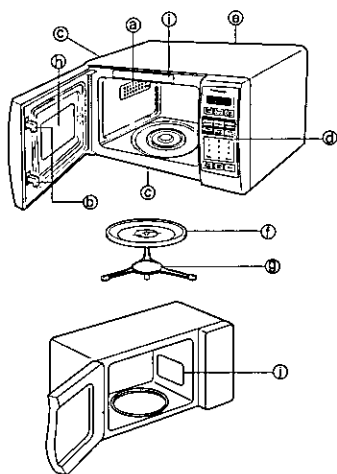

- (a) Internal Air Vents
- (b) Door Safety Lock System
- (c) External Air Vents
- (d) Control Panel
- (e) Identification Plate
- (f) Glass Tray
- (g) Rotating Ring
- (h) Heat/Vapor Barrier Film (do not remove)
- (i) Menu Label
- (j) Cover (do not remove)

Control Panel

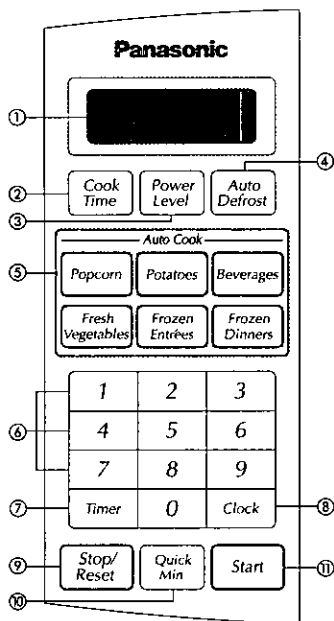

1. **DISPLAY WINDOW.** The display includes a clock and indicators that tell you time of day, cooking time settings, and cooking functions selected.
2. **COOK TIME PAD.** Touch this pad to set a cooking time.
3. **POWER LEVEL PAD.** Touch this pad to set a cooking power.
4. **AUTO DEFOST PAD.** Touch this pad to thaw meat, fish, or poultry by entering a weight.
5. **AUTO COOK PADS.**
6. **NUMBER PADS.** Touch number pads to enter cooking time, power level, quantities, or weights.
7. **TIMER PAD.** Touch this pad to use your microwave oven as a kitchen timer.
8. **CLOCK PAD.** Touch this pad to enter the time of day.
9. **STOP/RESET PAD.** Touch this pad to stop the oven or reset entries.
10. **QUICK MIN PAD.** Touch this pad to cook at 100% cook power for 1 minute to 30 minutes.
11. **START PAD.** Touch this pad to start all entries (except the auto cook and quick min function which start automatically) and to turn Child Lock on or off.

Beep Sound:

When a pad is pressed correctly, a beep will be heard.









If a pad is pressed and no beep is heard, the unit did not or cannot accept the instruction. The oven will beep twice between programmed stages. At the end of any complete program, the oven will beep.

Clock Setting

When your oven is plugged in or after a power interruption, 0 shows on the display.

Example: To set the clock for 11:11.

Touch: **Display Shows:**



1.  once. 
2.  once. 
3.  four times. 
4.  to start the clock. 

Quick Min Function

This time-saving feature lets you cook at 100% power for up to 30 minutes. 1 minute is added to the cook time whenever you press Quick Min.

Example: To cook for 1 minute.

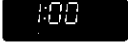
Touch: **Display Shows:**





1.  once. 
(Time counting down.)
2. At the end of the cook time, two short tones and one long tone will sound. The oven will stop. 

Child Safety Lock

You can use this safety feature to lock the control panel so that children cannot use the oven when you do not want them.



To set CHILD SAFETY LOCK:

Touch: **Display Shows:**

1.  once. 
2.  Hold until "L" appears in the display. 

To cancel CHILD SAFETY LOCK:

Touch: **Display Shows:**







-  Hold until "L" disappears from the display. 

Timer Setting

Your microwave oven can be used as a kitchen timer. You can set up to 99 minutes, 99 seconds.

Example: To set 3 minutes.

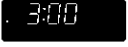
Touch: **Display Shows:**

1.  once. 
2.    
3.  to start the timer. (Time counting down.)

* If you want to cancel the TIMER, touch STOP/RESET during time counting down.













Power & Time Setting

This feature lets you program a specific cook time and power. For best results, there are 10 power level settings in addition to HIGH power (100%). Refer to the Microwave Power Level Chart for more information.

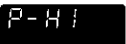
NOTE: If you do not select a power level, the oven will automatically cook at HIGH (100%) power.

Example: To cook for 5 minutes, 30 seconds at 80% power.

Touch: **Display Shows:**

1.  once. 
2.    
to set a cook time of 5 minutes, 30 seconds.
3.  once. 
4.  to set a cook power of 80%. 
5.  to start oven. 
(Time counting down.)
6. At the end of the cook time, two short tones and one long tone will sound. The oven will stop. 

MICROWAVE POWER LEVELS

Your microwave oven has 10 cook power levels to let you cook or heat a wide variety of foods. Refer to the chart below for suggestions:

Microwave Power Level Chart

Power Level	Use
10 (High)	<ul style="list-style-type: none"> • Boiling water. • Making candy. • Cooking poultry pieces, fish, & vegetables. • Cooking tender cuts of meat. • Whole poultry.
9	<ul style="list-style-type: none"> • Reheating rice, pasta, & vegetables.
8	<ul style="list-style-type: none"> • Reheating prepared foods quickly. • Reheating sandwiches.
7	<ul style="list-style-type: none"> • Cooking egg, milk, & cheese dishes. • Cooking cakes, breads. • Melting chocolate.
6	<ul style="list-style-type: none"> • Cooking veal. • Cooking whole fish. • Cooking puddings & custard.
5	<ul style="list-style-type: none"> • Cooking ham, whole poultry, & lamb. • Cooking rib roast, sirloin tip.
4	<ul style="list-style-type: none"> • Thawing meat, poultry, & seafood.
3	<ul style="list-style-type: none"> • Cooking less tender cuts of meat. • Cooking pork chops, roast.
2	<ul style="list-style-type: none"> • Taking chill out of fruit. • Softening butter.
1	<ul style="list-style-type: none"> • Keeping casseroles & main dishes warm. • Softening butter & cream cheese.
0	<ul style="list-style-type: none"> • Standing time.

Multi-Stage Cooking

For best results, some recipes call for different cook powers during different stages of a cook cycle. You can program your oven to switch from one power level to another for up to 3 stages.

NOTE: If you are using the AUTO DEFROST feature as one of the cooking stages, it must be programmed as the first stage.

Example: To set a 2-stage cook cycle.

Touch: **Display Shows:**

1. once.

2.

to set a 3 minute cook time for the first stage.

3. once.

4. to set an 80% cook power for the first stage.

5. once.

6.

to set a 7 minute cook time for second stage.

7. once.

8. to set an 50% cook power for the first stage.

9. to start the oven.

10. When the first stage is over, you will hear two short tones as the oven begins the second cook stage.

11. At the end of the cooking time, two short tones and one long tone will sound. The oven will stop.

Auto Defrost

AUTO DEFROST thaws frozen food without entering a cook time or cook power. Three defrost categories are preset in your oven: Ground Meat, Poultry, and Steaks/Chops. See the Auto Defrost Chart on the next page.

NOTES:

- For added convenience, AUTO DEFROST has a built-in reminder tone to tell you when to check, turn over, separate, or rearrange food. The oven will sound a tone during the defrost cycle. At the tone, open the door and turn, separate, or rearrange food. Remove any portions that have thawed. Return frozen portion to the oven and touch START to resume the defrost cycle.
- You can defrost foods that weigh 0.1 to 6.0 lbs.

For best results:

- Remove fish, shellfish, meat, and poultry from its original closed paper or plastic package (wrapper). Otherwise, the wrap will hold steam and juice close to the foods, which can cause the outer surface of the foods to cook.
- Shape ground meat into the form of a doughnut before freezing. When defrosting, remove thawed meat when the reminder tone sounds and continue defrosting.
- Place foods in a shallow container or on a microwave roasting rack to catch drippings.
- Food should still be somewhat icy in the center when removed from the oven.

Example: To defrost 1.2 lbs. of ground beef.

Touch: **Display Shows:**

1. once for Meat.

2.

to enter 1.2 lbs.

3. to start the oven. (Time counting down.)

4. At the end of the defrost time, two short tones and one long tone will sound. The oven will stop.

AUTO DEFROST CHART

Category	Touch keypad	Food to be Defrosted	At Reminder Tone	Standing Time
GROUND MEAT (dEF1)	1 time	Beef Ground beef	Turn over. Remove thawed portions and break apart. Return remainder to oven.	5 min.
		Cubes for stew	Turn over. Remove thawed portions with fork.	5 min.
		Hamburger patties	Turn over.	5 min.
		Pot roast	Turn over. Cover warm areas with aluminum foil.	10-20 min.
		Rib roast, Rump roast, Chuck roast	Same as above.	10-20 min. 10-20 min.
		Pork Bacon, Hot dogs	Turn over.	2 min.
		Sausage links	Turn over.	5 min.
		Sausage patties	Turn over.	5 min.
		Ribs, Roast	Turn over. Cover warm areas with aluminum foil.	10-20 min.
		Lamb Ribs	Turn over. Cover warm areas with aluminum foil.	10-20 min.
Roasts	Same as above.	10-20 min.		
POULTRY (dEF2)	2 times	Poultry Whole Chicken	Turn over. Finish defrosting breast-side down. Cover warm areas with aluminum foil.	10-20 min. Rinse under cold running water.
		Chicken Pieces Cornish Hens: Whole, Split	Separate pieces and rearrange. Turn over. Cover warm areas with aluminum foil.	5-10 min. 10-20 min. Rinse under cold running water.
		Turkey Breast (under 6 lbs.)	Turn over and arrange.	10-20 min. Rinse under cold running water.
STEAKS/ CHOPS (dEF3)	3 times	Beef Steaks	Turn over. Cover warm areas with aluminum foil.	10-20 min.
		Pork Chops	Same as above.	10-20 min.
		Lamp Chops	Same as above.	10-20 min.
		Fish	Turn over and rearrange. Cover head and tail with foil.	5 min.
		Steaks, whole fish fillets	Turn over. Separate fillets when partially thawed if possible.	5 min. Rinse with cold water to separate.
Shellfish Crabmeat, Shrimp Lobster tails Scallops	Rearrange and break apart. Turn over and rearrange. Turn over and rearrange.	5 min. 5 min. 5 min.		

Auto Cook

Use this function to cook food without entering a cook time or power. Refer to the Auto Cook Chart below for more information.

Example: To cook a 3.5 oz. bag of microwave popcorn.

Touch:

1.

Popcorn

once.

Display Shows:

3.5

2. The oven will start automatically. (Time counting down.)

3. At the end of cooking time two short tones and one long tone will sound. The oven will stop.

End

AUTO COOK CHART

NOTE: No cover is needed for the ONE TOUCH foods listed in this chart unless called for in the directions.

Pad	Touch keypad	Serving size	Directions
Popcorn	1 time	3.5 oz.	<ul style="list-style-type: none"> Follow package instructions. Use popcorn package which is made especially for microwave cooking. Do not try to pop unpopped kernels. Heat only 1 package at a time. Do not leave the microwave oven unattended while popping popcorn. <p>CAUTION: If pre-packaged popcorn is of a different weight than the recommended weight, do not use the preset popcorn settings. Set power level and time according to the manufacturer's instructions.</p>
	2 times	3.0 oz.	
	3 times	1.75 oz.	
Potatoes	1 time	1 piece (10 oz.)	<ul style="list-style-type: none"> Place in center of the oven on paper towel. Pierce potato several times with fork. After cooking, let stand for 5 minutes.
	2 times	2 pieces (20 oz.)	
	3 times	3 pieces (30 oz.)	
	4 times	4 pieces (40 oz.)	
Beverages	1 time	1 cup	<ul style="list-style-type: none"> Use mug or microwave-safe cup. Stir after reheating.
	2 times	2 cups	
Fresh Vegetables	1 time	1 cup	<ul style="list-style-type: none"> Prepare vegetable (wash and cut into 1/2-inch pieces). Most vegetables need 2 to 3 minutes standing time to finish cooking. 1 cup – Add 2 tablespoons water 2 cups – Add 1/4 cup water 3 cups – Add 1/3 cup water 4 cups – Add 1/2 cup water
	2 times	2 cups	
	3 times	3 cups	
	4 times	4 cups	
Frozen Entrées		10 oz.	<ul style="list-style-type: none"> Follow the package instructions. Example of one frozen entrée is Lasagna with Meat Sauce, Chicken with Rice, Sliced Turkey Breast with Rice and Vegetable.
Frozen Dinners	1 time	1 serving (8 oz.)	<ul style="list-style-type: none"> Arrange food on microwave plate. Place meaty portions and bulky vegetable to the outside of the plate. Cover with plastic wrap and vent. After cooking, let stand for 2 minutes.
	2 times	2 servings (16 oz.)	

Food Characteristics

Bone and Fat

Both bone and fat affect cooking. Bones may cause irregular cooking. Meat next to the tips of bones may overcook while meat positioned under a large bone, such as a ham bone, may be undercooked. Large amounts of fat absorb microwave energy and the meat next to these areas may overcook.

Density

Porous, airy foods such as breads, cakes or rolls take less time to cook than heavy, dense foods such as potatoes and roasts. When reheating donuts or other foods with different centers be very careful. Certain foods have centers made with sugar, water or fat and these centers attract microwaves (For ex., jelly donuts). When a jelly donut is heated, the jelly can become extremely hot while the exterior remains warm to the touch. This could result in a burn if the food is not allowed to cool properly in the center.

Quantity

Two potatoes take longer to cook than one potato. As the quantity of the food increases so does the cooking time. When cooking small amounts of food such as one or two potatoes, do not leave oven unattended. The moisture content in the food may decrease and a fire could result.

Shape

Uniform sizes heat more evenly. The thin end of a drumstick will cook more quickly than the meaty end. To compensate for irregular shapes, place thin parts toward the center of the dish and thick pieces toward the edge.

Size

Thin pieces cook more quickly than thick pieces.

Starting Temperature

Foods that are room temperature take less time to cook than if they are chilled or refrigerated or frozen.

Cooking Techniques

Piercing

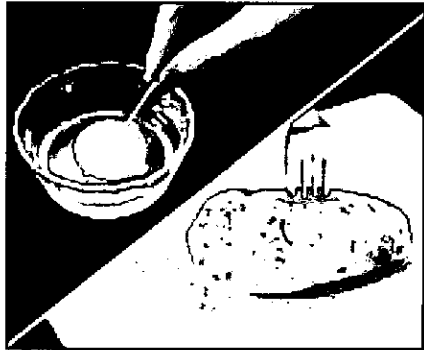

Foods with skins or membranes must be pierced scored or have a strip of skin peeled before cooking to allow steam to escape. Pierce whole egg yolks and whites, clams, oysters, chicken livers, whole potatoes and whole vegetables. Whole apples or new potatoes should have a 1-inch strip of skin peeled before cooking. Score sausages and frankfurters.

Browning



Foods will not have the same brown appearance as conventionally cooked foods or those foods which are cooked utilizing a browning feature. Meats and poultry may be coated with browning sauce, Worcestershire sauce, barbecue sauce or shake-on browning sauce. To use, combine browning sauce with melted butter or margarine; brush on before cooking. For quick breads or muffins, brown sugar can be used in the recipe in place of granulated sugar, or the surface can be sprinkled with dark spices before baking.

Cooking Techniques

Spacing

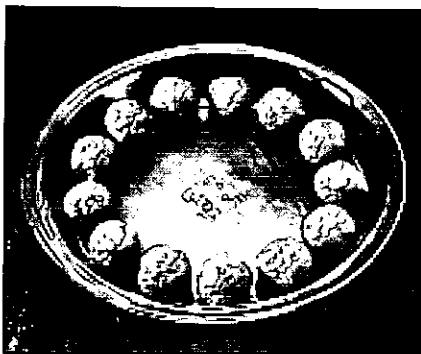

Individual foods, such as baked potatoes, cupcakes and appetizers, will cook more evenly if placed in the oven equal distances apart. When possible, arrange foods in a circular pattern.

Covering

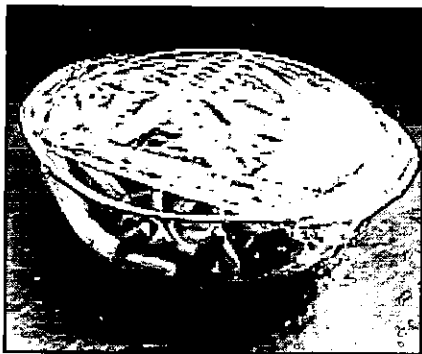

As with conventional cooking, moisture evaporates during microwave cooking. Casserole lids or plastic wrap are used for a tighter seal. When using plastic wrap, vent the plastic wrap by folding back part of the plastic wrap from the edge of the dish to allow steam to escape. Loosen or remove plastic wrap as recipe directs for stand time. When removing plastic wrap covers, as well as any glass lids, be careful to remove them away from you to avoid steam burns. Various degrees of moisture retention are also obtained by using wax paper or paper towels. However, unless specified, a recipe is cooked covered.

Cooking Techniques

Shielding

Thin areas of meat and poultry cook more quickly than meaty portions. To prevent overcooking, these thin areas can be shielded with strips of aluminum foil. Wooden toothpicks may be used to hold the foil in place.

Timing

A range in cooking time is given in each recipe. The time range compensates for the uncontrollable differences in food shapes, starting temperature and regional preferences. Always cook food for the minimum cooking time given in a recipe and check for doneness. If the food is undercooked, continue cooking. It is easier to add time to an undercooked product. Once the food is overcooked, nothing can be done.

Stirring

Stirring is usually necessary during microwave cooking. We have noted when stirring is helpful, using the words once, twice, frequently or occasionally to describe the amount of stirring necessary. Always bring the cooked outside edges toward the center and the less cooked center portions toward the outside of the dish.

Rearranging

Rearrange small items such as chicken pieces, shrimp, hamburger patties or pork chops. Rearrange pieces from the edge to the center and pieces from the center to the edge of the dish.

Turning

It is not possible to stir some foods to redistribute the heat. At times, microwave energy will concentrate in one area of a food. To help insure even cooking, these foods need to be turned. Turn over large foods, such as roasts or turkeys, halfway through cooking.

Stand Time

Most foods will continue to cook by conduction after the microwave oven is turned off. In meat cookery, the internal temperature will rise 5°F to 15°F (3°C to 8°C), if allowed to stand, tented with foil, for 10 to 15 minutes. Casseroles and vegetables need a shorter amount of standing time, but this standing time is necessary to allow foods to complete cooking to the center without overcooking on the edges.

Testing Doneness

The same tests for doneness used in conventional cooking may be used for microwave cooking. Meat is done when fork-tender or splits at fibers. Chicken is done when juices are clear yellow and drumstick moves freely. Fish is done when it flakes and is opaque. Cake is done when a toothpick or cake tester is inserted and comes out clean. Candy is done when it reaches the proper temperature for each stage of crystallization.

Using Your Microwave Oven

WARNING: Do not use aluminum foil during cooking cycle.

COOKING TIPS

Meat

1. No special techniques are required. Meat should be prepared as with conventional cooking. Season if desired. Always thoroughly defrost meat before cooking.
2. Place the meat on a microwave roasting rack or microwave-proof plate and place on the turntable.
3. Cook according to the Meat Cooking Chart (below). Use the longer time for large meats and the shorter time for smaller meats. For thicker chops, use the longer time.
4. Turn the meat once halfway through the cooking time.
5. **Let stand** for 5-10 minutes wrapped in foil after cooking. The standing time is very important as it completes the cooking process.
6. Make sure meat, especially pork, is thoroughly cooked before eating.

Meat Cooking Chart

Meat	Microwave Power	Cooking Time Per Pound
BEEF Standing/Rolled Rib		
- Rare	8	8 to 10 minutes
- Medium	8	9 to 11 minutes
- Well-done	8	10 to 13 minutes
Ground Beef (to brown for casserole)	HIGH(100%)	5½ to 8½ minutes
Hamburgers, Fresh or defrosted (4 oz. each)		
- 2 patties	HIGH(100%)	2 to 4 minutes
- 4 patties	HIGH(100%)	3 to 5 minutes
PORK Loin, Leg	8	11 to 15 minutes
Bacon		
- 4 slices	HIGH(100%)	2 to 3 minutes
- 6 slices	HIGH(100%)	3 to 4 minutes

NOTE: The times listed above are only a guide. Allow for difference in individual tastes and preferences. The times may also vary due to the shape, cut, and composition of the food.

Poultry

1. No special techniques are required. Poultry should be prepared as with conventional cooking. Season if desired.
2. Poultry should be thoroughly defrosted. Remove giblets and any metal clamps.
3. Prick the skin and brush lightly with vegetable oil unless the poultry is self-basting.
4. All poultry should be placed on a microwave roasting rack or a microwave-proof plate and placed on the turntable.
5. Cook according to the instructions in the Poultry Cooking Chart below. Turn over halfway through the cooking time. Because of its shape, poultry has a tendency to cook unevenly, especially in very bony parts. Turning during roasting helps to cook these areas evenly.
6. **Let stand** for 5-10 minutes wrapped in foil after cooking before carving. The standing time is very important, as it completes the cooking process.
7. Make sure poultry is thoroughly cooked before eating. Whole poultry is completely cooked when the juices run clear from the inside thigh when it is pierced with a sharp knife. Poultry pieces should be pierced with a sharp knife through the thickest part to ensure that the juices are clear and the flesh is firm.

Poultry Cooking Chart

Poultry	Microwave Power	Cooking Time Per Pound
CHICKEN Whole	8	10 to 14 minutes
Breast (boned)	8	9 to 13 minutes
Portions	8	10 to 16 minutes
TURKEY Whole	8	10 to 14 minutes

NOTES:

- The times listed above are only a guide. Allow for difference in individual tastes and preferences. The times may also vary due to the shape, cut, and composition of the food.
- If whole poultry is stuffed, the weight of the stuffed bird should be used when calculating the cooking time.

Using Your Microwave Oven

COOKING TIPS (continued)

Fish

1. Arrange fish in a large shallow non-metallic dish or casserole.
2. Cover with pierced microwave plastic wrap or casserole lid.
3. Place the dish on the turntable.
4. Cook according to the instructions in the Fresh Fish Cooking Chart below. Flakes of butter can be added to the fish if desired.
5. Let stand as directed in the Cooking Chart before serving.
6. After standing time, check to see that the fish is thoroughly cooked. The fish should be opaque and flake easily.

Fresh Fish Cooking Chart

Fish	Power	Cooking Time Per Pound	Method	Standing Time
Fish Fillets	HIGH	4 to 7 minutes	Add 15 to 30 ml (1 to 2 tbsp.) lemon juice	2 to 3 minutes
Whole Mackerel, Cleaned and Prepared	HIGH	4 to 7 minutes	-	3 to 4 minutes
Whole Trout, Cleaned and Prepared	HIGH	5 to 8 minutes	-	3 to 4 minutes
Salmon Steaks	HIGH	5 to 7 minutes	Add 15 to 30 ml (1 to 2 tbsp.) lemon juice	3 to 4 minutes

Heating or Reheating Guide

To heat or reheat successfully in the microwave, it is important to follow several guidelines. Measure the amount of food in order to determine the time needed to reheat. Arrange the food in a circular pattern for best results. Room temperature food will heat faster than refrigerated food. Canned foods should be taken out of the can and placed in a microwavable container. The food will be heated more evenly if covered with a microwavable lid or plastic wrap and vented. Remove cover carefully to prevent steam burns. Use the following chart as a guide for reheating cooked food.

Items	Cook time (at HIGH)	Special Instructions
Sliced meat 3 slices (1/4-inch thick)	1-2 minutes	Place sliced meat on microwavable plate. Cover with plastic wrap and vent. * Note: Gravy or sauce helps to keep meat juicy.
Chicken pieces 1 breast 1 leg and thigh	2-3 1/2 minutes 1 1/2-3 minutes	Place chicken pieces on microwavable plate. Cover with plastic wrap and vent.
Fish fillet (6-8 oz.)	2-4 minutes	Place fish on microwavable plate. Cover with plastic wrap and vent.
Lasagna 1 serving (10 1/2 oz.)	4-6 minutes	Place lasagna on microwavable plate. Cover with plastic wrap and vent.
Casserole 1 cup 4 cups	1-3 1/2 minutes 5-8 minutes	COOK covered in microwavable casserole. Stir once halfway through cooking.
Casserole – cream or cheese 1 cup 4 cups	1 1/2-3 minutes 3 1/2-5 1/2 minutes	COOK covered in microwavable casserole. Stir once halfway through cooking.
Sloppy Joe or Barbecued beef 1 sandwich (1/2 cup meat filling) without bun	1-2 1/2 minutes	Reheat filling and bun separately. Cook filling covered in microwavable casserole. Stir once. Heat bun as directed in chart below.
Mashed potatoes 1 cup 4 cups	1-3 minutes 5-8 minutes	COOK covered in microwavable casserole. Stir once halfway through cooking.
Baked beans 1 cup	1 1/2-3 minutes	COOK covered in microwavable casserole. Stir once halfway through cooking.
Ravioli or pasta in sauce 1 cup 4 cups	2 1/2-4 minutes 7 1/2-11 minutes	COOK covered in microwavable casserole. Stir once halfway through cooking.
Rice 1 cup 4 cups	1 1/2-3 1/2 minutes 4-6 1/2 minutes	COOK covered in microwavable casserole. Stir once halfway through cooking.
Sandwich roll or bun 1 roll	15-30 seconds	Wrap in paper towel and place on glass microwavable rack
Vegetables 1 cup 4 cups	1 1/2-2 1/2 minutes 4-6 minutes	COOK covered in microwavable casserole. Stir once halfway through cooking.
Soup 1 serving (8 oz.)	1 1/2-2 1/2 minutes	COOK covered in microwavable casserole. Stir once halfway through cooking.

Fresh Vegetable Chart

Vegetable	Amount	Cook time at HIGH	Instructions	Standing Time
Artichokes (8oz. each)	2 medium 4 medium	5-8 10-13	Trim. Add 2 tsp water and 2 tsp juice. Cover.	2-3 minutes
Asparagus, Fresh, Spears	1lb.	3-6	Add $\frac{1}{2}$ cup water. Cover.	2-3 minutes
Beans, Green & Wax	1 lb.	7-11	Add $\frac{1}{2}$ cup water in $1\frac{1}{2}$ qt. casserole. Stir halfway through cooking.	2-3 minutes
Beets, Fresh	1 lb.	12-16	Add $\frac{1}{2}$ cup water in $1\frac{1}{2}$ qt. covered casserole. Rearrange halfway through cooking.	2-3 minutes
Broccoli, Fresh, Spears	1lb.	4-8	Place broccoli in baking dish. Add $\frac{1}{2}$ cup water.	2-3 minutes
Cabbage, Fresh, Chopped	1lb.	4-7	Add $\frac{1}{2}$ cup water in $1\frac{1}{2}$ qt. covered casserole. Stir halfway through cooking.	2-3 minutes
Carrots, Fresh, Sliced	2 cups	2-4	Add $\frac{1}{4}$ cup water in 1 qt. covered casserole. Stir halfway through cooking.	2-3 minutes
Cauliflower, Fresh, Whole	1lb.	7-11	Trim. Add $\frac{1}{4}$ cup water in 1 qt. covered casserole. Stir halfway through cooking.	2-3 minutes
Flowerettes, Fresh Celery, Fresh, Sliced	2 cups 4 cups	$2\frac{1}{2}$ - $4\frac{1}{2}$ 6-8	Slice. Add $\frac{1}{2}$ cup water in $1\frac{1}{2}$ qt. covered casserole. Stir halfway through cooking.	2-3 minutes
Corn, Fresh	2 ears	5-9	Husk. Add 2 tbsp water in $1\frac{1}{2}$ qt. baking dish. Cover.	2-3 minutes
Mushrooms, Fresh, Sliced	$\frac{1}{2}$ lb.	2 - $3\frac{1}{2}$	Place mushrooms in $1\frac{1}{2}$ qt. covered casserole. Stir halfway through cooking.	2-3 minutes
Parsnips, Fresh, Sliced	1lb.	4-8	Add $\frac{1}{2}$ cup water in $1\frac{1}{2}$ qt. covered casserole. Stir halfway through cooking.	2-3 minutes
Peas, Green, Fresh	4 cups	7-10	Add $\frac{1}{2}$ cup water in $1\frac{1}{2}$ qt. covered casserole. Stir halfway through cooking.	2-3 minutes
Sweet Potatoes Whole Baking (6-8 oz. each)	2 medium 4 medium	5-10 7-13	Pierce potatoes several times with fork. Place on 2 paper towels. Turn over halfway through cooking.	2-3 minutes 2-3 minutes
White Potatoes, Whole Baking (6-8 oz. each)	2 potatoes 4 potatoes	5-8 10-14	Pierce potatoes several times with fork. Place on 2 paper towels. Turn over halfway through cooking.	2-3 minutes 2-3 minutes
Spinach, Fresh, Leaf	1lb.	4-7	Add $\frac{1}{2}$ cup water in 2 qt. covered casserole.	2-3 minutes
Squash, Acorn or Butternut, Fresh	1 medium	6-8	Cut squash in half. Remove seeds. Place in 8 x 8-inch baking dish. Cover.	2-3 minutes
Zucchini, Fresh, Sliced	1lb.	$4\frac{1}{2}$ - $7\frac{1}{2}$	Add $\frac{1}{2}$ cup water in $1\frac{1}{2}$ qt. covered casserole. Stir halfway through cooking.	2-3 minutes
Zucchini, Fresh, Whole	1lb.	6-9	Pierce. Place on 2 paper towels. Turn zucchini over and rearrange halfway through cooking.	2-3 minutes

Care of Your Microwave Oven

BEFORE CLEANING:

Unplug at socket of the oven. If impossible, leave oven door open to prevent oven from accidentally turning on.

AFTER CLEANING:

Be sure to replace the Rotating Ring and Glass Tray in the proper position and press **Stop/Reset Pad** to clear the screen.

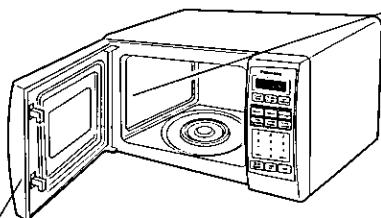

INTERIOR

Wipe the oven inside and outside with a soft cloth and a mild detergent solution. Then rinse and wipe dry. This should be done weekly or more often, if needed. Never use cleaning powders or rough pads. Excessive oil splatters on the inside top will be difficult to remove if left for many days. Wipe splatters with a wet paper towel, especially after cooking chicken or bacon.

REMOVABLE PARTS

The turntable and rotating ring are removable. They should be hand-washed in warm (not hot) water with a mild detergent and a soft cloth. Once they are clean, rinse well and dry with a soft cloth. Never use cleaning powders, steel wool, or rough pads.

- The turntable may be cleaned at the sink. Be careful not to chip or scratch the edges as this may cause the turntable to break during use.
- The rotating ring should be cleaned regularly.

DOOR

For best performance and safety, the inner door panel and the oven front frame should be free of food or grease buildup. Wipe often with a mild detergent; then rinse and wipe dry. Never use cleaning powders or rough pads.

Before Requesting Service

All these things are normal:

The oven causes interference with my TV.

Some radio and TV interference might occur when you cook with the microwave oven. This interference is similar to the interference caused by small appliances such as mixers, vacuums, blow dryers, etc. It does not indicate a problem with your oven.

Steam accumulates on the oven door and warm air comes from the oven vents.

During cooking, steam and warm air are given off from the food. Most of the steam and warm air are removed from the oven by the air which circulates in the oven cavity. However, some steam will condense on cooler surfaces such as the oven door. This is normal.

I accidentally ran my microwave oven without any food in it.

Running the oven empty for a short time will not damage the oven. However, we do not recommend operating the microwave oven without any food in it.

The oven lights dim.

When cooking with a power other than HIGH, the oven must cycle to obtain the lower power levels. The oven light will dim and clicking noises can be heard when the oven cycles.

PROBLEM	POSSIBLE CAUSE	REMEDY
Oven will not turn on.	The oven is not plugged in securely.	Remove plug from outlet, wait 10 seconds and reinsert.
	Circuit breaker or fuse is tripped or blown.	Reset circuit breaker or replace fuse.
	There is a problem with the outlet.	Plug another appliance into the outlet to check if it is working.
Oven will not start cooking.	The door is not closed completely.	Close the oven door securely.
	Start Pad was not pressed after programming.	Press Start Pad .
	Another program is already entered into the oven.	Press Stop/Reset Pad to cancel the previous program and enter new program.
	The program is not correct.	Program again according to the Operating Instructions.
The Glass Tray wobbles.	Stop/Reset Pad has been pressed accidentally.	Program oven again.
	The Glass Tray is not positioned properly on the Rotating Ring or there is food under the Rotating Ring.	Take out Glass Tray and Rotating Ring. Wipe with a damp cloth and reset Rotating Ring and Glass Tray properly.
When the oven is operating, there is noise coming from the Glass Tray.	The Rotating Ring and oven bottom are dirty.	Clean these parts according to Care of Your Microwave Oven .
The word "L" appears in the Display Window.	The CHILD LOCK was activated by pressing 0 pad.	Hold "0" pad until "L" disappears from the display.

Limited Warranty & Customer Services

PANASONIC CONSUMER ELECTRONICS COMPANY,
DIVISION OF MATSUSHITA ELECTRIC
CORPORATION OF AMERICA
One Panasonic Way
Secaucus, New Jersey 07094

PANASONIC SALES COMPANY,
DIVISION OF MATSUSHITA
ELECTRIC OF PUERTO RICO, INC.,
Ave. 65 de Infanteria, Km. 9.5
San Gabriel Industrial Park
Carolina, Puerto Rico 00985

Panasonic Microwave Oven Product Limited Warranty

Limited Warranty Coverage

If your product does not work properly because of a defect in materials or workmanship, Panasonic Consumer Electronics Company or Panasonic Sales Company (collectively referred to as "the warrantor") will, for the length of the period indicated on the chart below, which starts with the date of original purchase ("warranty period"), at its option either (a) repair your product with new or refurbished parts, or (b) replace it with a new or a refurbished product. The decision to repair or replace will be made by the warrantor.

	<u>PARTS</u>	<u>LABOR</u>
ALL PARTS(EXCEPT MAGNETRON TUBE)	1 (ONE) YEAR	1 (ONE) YEAR
MAGNETRON TUBE	5 (FIVE) YEAR	1 (ONE) YEAR

During the "Labor" warranty period there will be no charge for labor. During the "Parts" warranty period, there will be no charge for parts. You must carry-in or mail-in your product during the warranty period. This warranty only applies to products purchased and serviced in the United States or Puerto Rico. This warranty is extended only to the original purchaser of a new product which was not sold "as is". A purchase receipt or other proof of the original purchase date is required for warranty service.

Carry-In or Mail-In Service

For Carry-In or Mail-In Service in the United States call 1-800-211-PANA(7262) or visit Panasonic Web Site: <http://www.panasonic.com>

For assistance in Puerto Rico call Panasonic Sales Company (787)-750-4300 or fax (787)-768-2910.

Limited Warranty Limits And Exclusions

This warranty ONLY COVERS failures due to defects in materials or workmanship, and DOES NOT COVER glass, plastic parts, temperature probes(if included) and normal wear and tear or cosmetic damage. The warranty ALSO DOES NOT COVER damages which occurred in shipment, or failures which are caused by products not supplied by the warrantor, or failures which result from accidents, misuse, abuse, neglect, mishandling, misapplication, alteration, faulty installation, set-up adjustments, misadjustment of consumer controls, improper maintenance, power line surge, lightning damage, modification, or commercial use (such as in a hotel, office, restaurant, or other business), rental use of the product, service by anyone other than a Factory Servicenter or other Authorized Servicer, or damage that is attributable to acts of God.

Limited Warranty & Customer Services

THERE ARE NO EXPRESS WARRANTIES EXCEPT AS LISTED UNDER "LIMITED WARRANTY COVERAGE". THE WARRANTOR IS NOT LIABLE FOR INCIDENTAL OR CONSEQUENTIAL DAMAGES RESULTING FROM THE USE OF THIS PRODUCT, OR ARISING OUT OF ANY BREACH OF THIS WARRANTY. (As examples, this excludes damages for lost time, cost of having someone remove or re-install an installed unit if applicable, or travel to and from the servicer. The items listed are not exclusive, but are for illustration only.) **ALL EXPRESS AND IMPLIED WARRANTIES, INCLUDING THE WARRANTY OF MERCHANTABILITY, ARE LIMITED TO THE PERIOD OF THE LIMITED WARRANTY.**

Some states do not allow the exclusion or limitation of incidental or consequential damages, or limitations on how long an implied warranty lasts, so the exclusions may not apply to you.

This warranty gives you specific legal rights and you may also have others rights which vary from state to state. If a problem with this product develops during or after the warranty period, you may contact your dealer or Servicenter. If the problem is not handled to your satisfaction, then write to the warrantor's Consumer Affairs Department at the addresses listed for the warrantor.

PARTS AND SERVICE WHICH ARE NOT COVERED BY THIS LIMITED WARRANTY ARE YOUR RESPONSIBILITY.

*For Product Information, Operating Assistance, Literature Request, Dealer Locations, and all Customer Service inquiries please contact:
1-800-211-PANA (7262), Monday-Friday 9 am-9 pm; Saturday-Sunday 9 am-7 pm, EST.*

*Web Site: <http://www.panasonic.com>
You can purchase parts, accessories or locate your nearest servicer by visiting our Web Site.*

Accessory Purchases:

1-800-332-5368 (Customer Orders Only)
Panasonic Services Company 20421 84th Avenue South, Kent, WA 98032
(6 am to 5 pm Monday-Friday; 6 am to 10:30 am Saturday; PST)
(Visa, MasterCard, Discover Card, American Express, Check)

Service in Puerto Rico

*Matsushita Electric of Puerto Rico, Inc. Panasonic Sales Company/Factory Servicenter:
Ave. 65 de Infantería, Km. 9.5, San Gabriel Industrial Park, Carolina, Puerto Rico 00985
Phone (787) 750-4300 Fax (787) 768-2910*

INSTRUCCIONES DE SEGURIDAD

Su horno de microondas es un artículo para cocinar y usted debe usarlo con tanto cuidado como usa una estufa o cualquier otro artículo para cocinar.

Cuando utilice este aparato eléctrico, se deben seguir precauciones básicas de seguridad, incluyendo las siguientes:

PRECAUCIÓN—To reduce the risk of burns, electric shock, fire, injury to persons, or exposure to excessive microwave energy:

1. Lea todas las instrucciones antes de usar el aparato.
2. Lea y siga las "PRECAUCIONES PARA EVITAR POSIBLE EXPOSICION EXCESIVA A ENERGIA DE MICROONDAS" específicas, que se encuentran abajo.
3. Este aparato debe ser conectado a tierra. Conecte solamente a la toma eléctrica debidamente conectada a tierra. Vea las "INSTRUCCIONES PARA CONEXIÓN A TIERRA" que se encuentran en la página 24.
4. Instale o ubique este aparato solamente de acuerdo con las instrucciones de instalación que se encuentran en la página 25.
5. No cubra ni tape ninguna de las rendijas de este aparato.
6. No almacene o use este aparato en exteriores. No use este aparato cerca del agua - por ejemplo, cerca del fregadero de la cocina, en una base mojada, o cerca de una alberca, y similares.
7. Use este aparato sólo para los fines para los que fué hecho, tal como se describen en este manual. No use químicos o vapores corrosivos en este aparato. Este tipo de horno está específicamente diseñado para calentar o cocinar alimentos. No fué diseñado para uso industrial o de laboratorio.
8. Cuando limpie las superficies de la puerta y el horno que vienen juntas al cerrar la puerta, use solamente jabones no abrasivos o detergentes suaves aplicados con una esponja o con tela suave.
9. No permita a los niños usar este aparato, a menos que sean supervisados muy de cerca por un adulto.
10. No use este aparato si tiene dañado el cordón o la clavija, si no está trabajando adecuadamente, o si ha sido dañado o se ha dejado caer.
11. No sumergir en agua el cable o la clavija.
12. Mantenga el cordón lejos de superficies calientes.
13. No deje el cordón colgando en el borde de la mesa o mostrador.
14. Este aparato debe recibir mantenimiento sólo de personal calificado. Contacte las instalaciones de servicio autorizadas más cercanas para revisión, reparación o ajuste.
15. Algunos productos, tales como los huevos completos y contenedores sellados - por ejemplo frascos de vidrio cerrados - pueden explotar y no deben ser calentados en este horno.
16. Para reducir el riesgo de incendio en la cavidad del horno:
 - (a) No sobrecoque los alimentos. Preste atención cuidadosamente al aparato. El papel, plástico u otros materiales combustibles son colocados dentro del horno para facilitar la cocción pero si no se utilizan adecuadamente esto puede producir incendio en su horno.
 - (b) Quite los sujetadores de alambre de las bolsas de papel o plástico antes de colocar la bolsa en el horno.
 - (c) Quite los sujetadores de alambre de las bolsas de papel o plástico antes de colocar la bolsa en el horno.
 - (d) No use la cavidad con propósitos de almacenaje. No deje productos de papel, utensillos de cocina o alimentos en la cavidad cuando no esté en uso.

Guardé estas instrucciones

PRECAUCIONES PARA EVITAR POSIBLE EXPOSICION EXCESIVA A ENERGIA DE MICROONDAS

- (a) No intente hacer funcionar este horno con la puerta abierta ya que esto puede resultar peligroso. Es importante no anular o biogear los mecanismos de seguridad.
- (b) No coloque ningún objeto entre el panel frontal del horno y la puerta, ni permita que se acumule basura o residuos de limpiadores en las superficies de sellado.
- (c) No haga funcionar el horno si está dañado, es importante que la puerta del horno abra y cierre apropiadamente:
 - (1) la puerta (combada)
 - (2) bisagras y seguro de la puerta (rotos o sueltos)
 - (3) sellos de las puertas y superficies de sellado
- (d) El horno o deberá ser ajustado o reparado por ninguna persona, excepto el personal de servicio debidamente calificado.

INSTRUCCIONES DE SEGURIDAD

Uso General

1. **NO** altere o haga ningún ajuste o reparación a la puerta, al alojamiento del panel de control, interruptores entrecruzados de seguridad o a cualquier otra parte del horno. **NO** quite el panel exterior del horno. Las reparaciones deben ser hechas solamente por personal de servicio calificado.
2. **NO** opere el horno vacío. La energía de microondas se reflejará continuamente a través del horno si los alimentos o agua no están presentes para absorber energía. Esto puede dañar el horno y resultar en peligro de incendio.
3. **NO** utilice este horno para calentar químicos o cualquier otros productos no alimenticios. **NO** limpie este horno con cualquier producto etiquetado con contenido químico corrosivo. El calentamiento de químicos corrosivos en este horno puede causar fugas de radiación.
4. **NO** seque telas, periódicos u otros materiales en el horno. Pueden incendiarse.
5. **NO** use productos de papel reciclado, ya que pueden contener impurezas que pueden causar chispas y/o incendios cuando se usen.
6. **NO** use periódicos o bolsas de papel para cocinar. Puede causar un incendio.
7. **NO** pegue, **NO** golpee el panel de control. Pueden causarse daños a los controles. Puede causar un incendio.
8. Las manoplas para tomar cosas calientes siempre deben ser utilizados cuando se retiren cosas de el horno. El calor se transfiere de los alimentos calientes a los contenedores para cocinar y de los contenedores a la Bandeja de Cristal. La Bandeja de Cristal puede estar muy caliente después de sacar los contenedores para cocinar del horno.
9. **NO** almacene materiales flamables cerca, arriba, o dentro del horno. Pueden ser riesgos de incendio.

INSTRUCCIONES PARA CONEXIÓN A TIERRA

Este aparato debe ser conectado a tierra. En el caso de un corto circuito, la conexión a tierra reduce el riesgo de una descarga eléctrica proporcionando una línea de escape para la corriente eléctrica. Este aparato está equipado con un cable y clavija para conexión a tierra. La clavija debe ser conectada en un receptor que esté instalado adecuadamente y conectado a tierra.

PRECAUCION - El uso inapropiado de la clavija para conexión a tierra puede resultar en riesgo de descarga eléctrica.

Consulte a un electricista o a personal de servicio calificados, si las instrucciones para conectar a tierra no son completamente comprendidas o si existe duda de que el aparato está correctamente conectado a tierra. Si es necesario usar un cable de extensión, use solamente cable de extensión de tres hilos que tenga una clavija de tres entradas para conectar a tierra, y un receptor de tres ranuras que acepte la clavija del aparato. El calibre marcado en el cable de extensión debe ser igual o mayor al calibre eléctrico del aparato.

Suministro Eléctrico

1. Se provee un cable de suministro eléctrico corto para reducir los riesgos resultantes de enredarse o tropezarse con un cable más largo.
2. Juegos de cable más largos o extensiones están disponibles y pueden utilizarse si se usan con cuidado.
3. Si se usa un cable más largo o extensión, (1) el calibre eléctrico marcado en el juego de cordón o extensión debe ser al menos tan grande como el calibre eléctrico del aparato, (2) el cable de extensión debe ser de tres hilos del tipo de conexión a tierra, y (3) el cordón más largo debe ser arreglado de tal forma que no caiga sobre la cubierta del mostrador o de la mesa donde pueda ser jalado por niños o tropezarse accidentalmente.

INSTRUCCIONES DE INSTALACIÓN

Examine Su Horno

Desempaque el horno, quite todo el material de empaque y examine que su horno no tenga ningún daño, tales como abolladuras, seguros de la puerta rotos o resquebrajadas en la puerta. Notifique inmediatamente a su distribuidor si el horno está dañado.

Ubicación del Horno

1. El horno debe ser colocado en una superficie plana y estable. Para su operación apropiada, el horno debe tener suficiente corriente de aire. Deje 10 cm de espacio de ambos lados del horno y 10 cm de espacio en la parte superior del horno.

a. **NO** bloquear la ventilación del aire.

Si es bloqueada la ventilación del aire durante la operación, el horno puede sobre calentarse y quemarse.

Cuando use algún trapo, franela o funda para cubrir el horno, las tomas y salidas del aire no deberán ser bloqueadas. También debe tener un espacio apropiado para la parte trasera y los costados.

b. **NO** coloque el horno cerca de una superficie húmeda caliente, tal como un registro de gas o eléctrico.

c. **NO** opere el horno cuando la humedad del cuarto sea muy alta.

2. Este horno ha sido fabricado para uso en el hogar solamente.

Interferencia de Radio

1. La operación de su horno de microondas puede causar interferencia en su radio, TV o equipo similar.

2. Cuando hay interferencia, se puede reducir o eliminar tomando las siguientes medidas:

a. Limpie la puerta y las superficies selladoras del horno.

b. Ponga el radio, TV, etc. lo más lejos posible del horno de microondas.

c. Use una antena instalada adecuadamente para obtener una recepción de señal más fuerte.

Requerimientos de cableado

1. El horno debe estar en un circuito separado. Ningún otro aparato debe compartir el circuito con el horno. Si lo hace el fusible del circuito puede estallar, el bloqueador del circuito trabarse o la comida cocinarse más lento que en los tiempos recomendados en este manual.
2. El voltaje usado debe ser el mismo al especificado en el horno de microondas (120 V.). Usar un voltaje más alto es peligroso y puede resultar en fuego u otro accidente causando daño al horno. Usar un bajo voltaje dará como resultado un cocinado más lento. Panasonic no se hace responsable por daños resultantes del uso del horno con otros voltajes que no sea el especificado.
3. El horno debe ser conectado en un enchufe a tierra de al menos 20 amp 120 volt, 60 Hz. Donde se encuentre un enchufe estándar de 2 entradas es responsable y obligación del consumidor reemplazarlo por un enchufe a tierra de 3 entradas.



Especificaciones Técnicas

NN-S432WL/BL	
Potencia Fuente de Poder:	13,0 Amps, 1500 W
Potencia de Salida:*	1100 W
Dimensiones Exteriores (Alto x Ancho x Fondo):	303,8 x 514,7 x 408 mm
Dimensiones Cavity del Horno (Alto x Ancho x Fondo):	236 x 353 x 361 mm
Frecuencia:	2450 MHz
Peso Sin Embalaje:	Aprox. 15,0 kg

*Determinado de acuerdo a procedimientos contemplados en la normal IEC 60705.

Las especificaciones están sujetas a cambios sin previo aviso.

Sugerencias Útiles

Siga Esta Precauciones de Seguridad Cuando Cocine en Su Horno

IMPORTANTE

La cocción adecuada depende del tiempo designado y del peso de los alimentos. Si usa una porción menor de la recomendada y cocina por el tiempo para la porción recomendada, puede resultar un incendio. Si ocurre un incendio, ponga el horno en posición de apagado y manténgalo cerrado. Desconecte la energía eléctrica o desconecte la caja de fusibles o el panel de control.

1) ENLATADO CASERO/ALIMENTOS DESHIDRATADOS/PEQUEÑAS CANTIDADES DE ALIMENTOS

- No use su horno para el enlatado casero o para calentar cualquier frasco cerrado. La presión aumentará y el frasco puede explotar. Su horno no puede mantener los alimentos a la temperatura apropiada de enlatado.
- Pequeñas cantidades de alimento o alimentos con bajo contenido de humedad se pueden secar, quemar o incendiarse.
- No seque alimentos, hierbas, frutas o vegetales en su horno.

2) PALOMITAS DE MAÍZ

Las palomitas de maíz deben prepararse en un recipiente para palomitas de maíz adecuado para horno de microondas. Palomitas de maíz para horno de microondas que se preparan en su propio paquete también están disponibles. Siga las instrucciones del fabricante de palomitas de maíz y use una marca adecuada para la potencia de su horno de microondas. Nunca deje desatendido el horno cuando prepare palomitas de maíz.

PRECAUCIÓN

Cuando use palomitas de maíz para microondas previamente empacado siga las instrucciones recomendadas en el paquete. Revise el peso del paquete antes de usar la tecla de palomitas de maíz. Prepare el horno para el peso del paquete de palomitas de maíz. Si no se siguen estas instrucciones, las palomitas de maíz pueden no reventar adecuadamente o pueden encenderse y causar un incendio.

3) FREIR CON MUCHA GRASA

- No trate de freir con mucha grasa en su horno de microondas. Cocinar aceites puede estallar en flamas y puede causar daño al horno y quizá acabar en quemaduras. Los utensilios de microondas pueden no ser útiles para soportar la temperatura del aceite caliente, y podrían romperse.

4) HUEVOS

- No caliente huevos en su cascarón en el horno de microondas. La presión subirá y el huevo explotará.

5) ALIMENTOS CON PIELS NO POROSAS

- Papas, manzanas, yemas de huevo, calabazas completas y salchichas son ejemplos de alimentos con pieles no porosas. Estos tipos de alimentos deben ser perforados antes de cocinarlos en Microondas para evitar que Estallen.

- Use papas frescas para hornear y cocínelas hasta que estén listas. Cocinar demasiado causa deshidratación y puede producir un incendio. Use los pesos recomendados o puede ocurrir un incendio.

6) LIQUIDOS

- Los líquidos pueden "sobrecalentarse" en el microondas y, cuando el recipiente se desplaza en un sentido, los líquidos sobrecalentados pueden "desbordarse" fuera del recipiente. El agua "sobrecalentada" es más caliente que el agua hervida, AUNQUE NO HAGA BURBUJAS. Para reducir la posibilidad de que esto ocurra, siempre debe agitar con fuerza los líquidos antes de calentarlos para que el líquido se mezcle con aire. **NO CALIENTE NUNCA LOS LIQUIDOS DURANTE UN TIEMPO PROLONGADO.**

7) BANDEJA DE CRISTAL/UTENSILIOS DE COCINA/PAPEL ALUMINIO

- Los utensilios para cocinar se calientan durante la cocción en microondas. Use soportes para lo caliente, cuando saque los utensilios del horno o cuando quite tapas o cubiertas de envoltura de plástico de los utensilios de cocina, para evitar quemaduras.
- La bandeja de cristal se calentará durante la cocción. Debe permitirse que se enfríe antes de manejarla o antes de colocar productos de papel, tales como platos de papel o bolsas de palomitas de maíz para microondas, para cocinar.
- Cuando se use papel aluminio, brochetas, rejillas para calentar o utensilios hechos de metal en el horno, deje por lo menos 2,5 cm de espacio entre el material de metal y las paredes interiores del horno. Si arquee (chispea) quite el material de metal (brochetas etc.) y/o cambie a un contenedor no metálico.
- Platos con adornos metálicos no deberan ser usados, ya que puede producirse arco eléctrico.

8) TOALLAS DE PAPEL/TELAS

- No use toallas de papel o telas que contengan fibras sintéticas en su tejido. La fibra sintética puede causar que la toalla se incendie.
- No use bolsas de papel o productos de papel reciclado en el horno de microondas.

9) BANDEJA DORADOR/BOLSAS PARA COCINAR EN HORNO

- Los bandeja doradora o asados son diseñados para cocinar en microondas solamente. Siempre siga las instrucciones dadas por el fabricante. No precaliente la bandeja doradora mas de 8 min.
- Si se usa una bolsa para cocinar para el microondas, prepare de acuerdo a las instrucciones del paquete. No use sujetadores de alambre para cerrar la bolsa.

10) TERMÓMETROS

- No use termómetros convencionales para alimentos en su horno. Puede producir arco.

11) GUÍA DE USO GENERAL DEL HORNO/PUERTA DEL HORNO

- No use el horno por cualquier razón que no sea la preparación de alimentos.
- No deje sin atención el horno mientras esté en uso.

Panel de Control

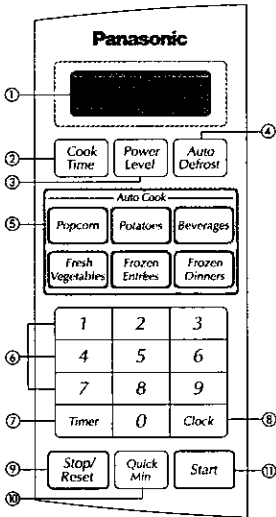

- (1) Pantalla indicadora (Ventana de Visualización)
- (2) Cocción a tiempo programado
- (3) Pulsador de potencia
- (4) El auto deshelar
- (5) Pulsadores de auto cocción
- (6) Pulsadores de numéricos
- (7) Pulsador de tiempo
- (8) Pulsador de reloj
- (9) Pulsador Para Pausa/Cancelar
- (10) Pulsador de rapido en minutos
- (11) Pulsador Para Comenzar

El poder & el tiempo poniendo

Este elemento le permite programar un tiempo y una intensidad de cocción. Para resultados óptimos hay 10 niveles de intensidad además de intensidad alta (HIGH) que es el 100%. Para más información referirse a la Cuadro de niveles de intensidad de microondas.

NOTA: Si Ud. no selecciona el nivel de intensidad, el horno cocinará automáticamente a 100% de intensidad (HIGH).

Ejemplo: Para cocinar por 5 minutos, 30 segundos a 80% de intensidad.

Toque: La pantalla muestra:

1. una vez.

2.

para programar el reloj en 5 minutos y 30 segundos.

3. una vez.

4. para programar la intensidad al 80%.

5. para que el horno comience a funcionar.

6. Al final del período de cocción, habrá dos sonidos cortos y uno largo. El horno se detendrá.

NIVELES DE INTENSIDAD DE LAS MICROONDAS

Su horno de microondas tiene 10 niveles de intensidad de cocción para permitirle cocinar o calentar una variedad de alimentos. En el siguiente cuadro se muestran algunas sugerencias:

Cuadro de nivel de intensidad de microondas























Nivel de intensidad	Uso
10 (High)	<ul style="list-style-type: none">• Hervir agua.• Hacer caramelo.• Cocinar trozos de aves, pescado y verduras.• Cocinar trozos tiernos de carne.• Cocinar aves enteras.
9	<ul style="list-style-type: none">• Recalentar arroz, pastas y verduras.
8	<ul style="list-style-type: none">• Recalentar comidas preparadas rápidamente.• Recalentar emparedados.
7	<ul style="list-style-type: none">• Cocinar platos a base de huevos, leche y queso.• Cocinar pasteles, pan.• Derretir chocolate.
6	<ul style="list-style-type: none">• Cocinar ternera.• Cocinar un pescado entero.• Cocinar budines y natillas.
5	<ul style="list-style-type: none">• Cocinar jamón, aves enteras, cordero.• Cocinar asado de costilla, puntas de filete.
4	<ul style="list-style-type: none">• Descongelar carne, aves y mariscos.
3	<ul style="list-style-type: none">• Cocinar cortes de carne menos tierna.• Cocinar chuletas de cerdo, asado.
2	<ul style="list-style-type: none">• Quitarle el frío a las frutas.• Ablandar mantequilla.
1	<ul style="list-style-type: none">• Mantener guisados y platos principales tibios.• Ablandar manteca y queso crema.
0	<ul style="list-style-type: none">• Tiempo de reposo.

Trace para el cocinero automático







NOTA: Para cocinar los alimentos de la lista no se necesita tapar.

Botón	Toque el botón	Porción	Instrucciones
POPCORN (Palomitas de maíz)	1 vez 2 veces 3 veces	3.5 oz. 3.0 oz. 1.75 oz.	<ul style="list-style-type: none"> • Siga las instrucciones del paquete. • Use palomitas especiales para microondas. • No trate de hacer reventar los granos de ma z que no han reventado. • Caliente un s lo paquete por vez. • No deje el horno descuidado mientras hace palomitas de maíz. <p>CUIDADO: Si pre palomitas de maíz embaladas son de un peso diferente que el peso recomendado, no usa el fijo las colocaciones de palomitas de maíz. El nivel fijo del poder y el tiempo segun las instrucciones del fabricante.</p>
POTATOES (Papas)	1 vez 2 veces 3 veces 4 veces	1 (10 oz.) 2 (20 oz.) 3 (30 oz.) 4 (40 oz.)	<ul style="list-style-type: none"> • Colóquelas en el centro del horno sobre una toalla de papel. • Pique la papa varias veces con un tenedor. • Luego de cocinar, deje reposar por 5 minutos.
BEVERAGES (Bebidas)	1 vez 2 veces	1 taza 2 tazas	<ul style="list-style-type: none"> • Use una taza o vaso para microondas. • Revuelva despu s de recalentar.
FRESH VEG-ETABLES (Las verduras frescas)	1 vez 2 veces 3 veces 4 veces	1 copa 2 copas 3 copas 4 copas	<ul style="list-style-type: none"> • Prepare verdura (el lavado y el corte en pedazos 1/2-inch). • La mayoría de las verduras necesitan 2 a 3 minutos tiempo que se para para acabar de cocina. 1 copa – Agregue 2 agua de cucharones 2 copas – Agregue copa 1/4 agua 3 copas – Agregue copa 1/3 agua 4 copas – Agregue copa 1/2 agua
FROZEN ENTRÉES (Entrees con gelado)		10 oz.	<ul style="list-style-type: none"> • Siga las instruccione de paquete. • El ejemplo de un entrees congelado es lasagna con la salsa de carne, el poll o con arroz, seno cortado de pavo con arroz y verdura.
FROZEN DINNERS (Las cenas congeladas)	1 vez 2 veces	1 porción (8 oz.) 2 porciones (16 oz.)	<ul style="list-style-type: none"> • Arregle alimento en el plato de microwave. • Coloque las porciones de meaty y verdura voluminosa al exterior del plato. • La cubierta con plástico envuelve y la abertura. • Después que cocinar, permitió significar 2 minutos.

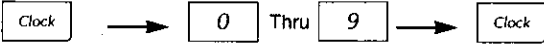
GUIA RAPIDA DE OPERACIÓN

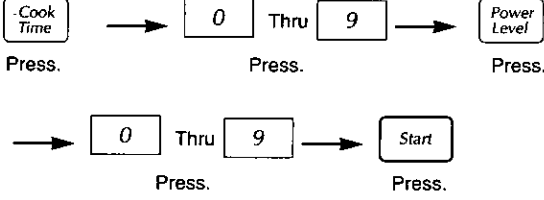
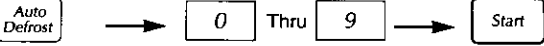
Característica	Como Opera	
Para Poner el Reloj en la Hora	 →  a  →  Presione. Registre la hora o día. Presione.	
Minuto Automático	 (hasta a 30)	
Para Ajuste de Potencia y Tiempo	 →  a  →  Presione. Presione. Presione.	
	 a  →  Presione. Presione.	
Para Descongelar usando el pulsador	 →  a  →  Presione. Fije el peso. Presione.	
A la cerradura de la Seguridad del niño del uso.	 tenga "0" hasta que "L" aparezca en el despliegue.	 tenga "0" hasta que "L" desaparezca en el despliegue.
Para Cocinar usando el Pulsador Auto Cocción	eg.  Seleccione porciones/peso.	
Para Usar como en temporizador de cocina	 →  a  →  Presione. Presione.	

QUICK GUIDE TO OPERATION

Feature	How to Operate
To Set Clock	 <p style="text-align: center;">Press. Enter time of day. Press.</p>
To Cook using Quick Min Pad	 <p style="text-align: center;">(up to 30 min.)</p>
To Cook using Power & Time setting	 <p style="text-align: center;">Press. Press. Press.</p> <p style="text-align: center;">Press. Press.</p>
To Defrost using Auto Defrost Pad	 <p style="text-align: center;">Press. Set weight. Press.</p>
To use Child Safety Lock	<div style="display: flex; justify-content: space-around;"> <div style="text-align: center;">  <p>Hold "0" Pad until "L" appears in the display.</p> </div> <div style="text-align: center;">  <p>Hold "0" Pad until "L" disappears in the display.</p> </div> </div>
To Cook using	<p>eg. </p> <p>Select Serving/Weight.</p>
To Use as a Kitchen Timer	 <p style="text-align: center;">Press. Press.</p>

Panasonic Consumer Electronics Company, Division of Matsushita Electric Corporation of America
 One Panasonic Way
 Secaucus, New Jersey 07094

Panasonic Sales Company, Division of Matsushita Electric of Puerto Rico, Inc. ("PSC")
 Ave. 65 de Infanteria, Km. 9.5
 San Gabriel Industrial Park,
 Carolina, Puerto Rico 00985